

BOSS GT 100 / Marshall JVM / 4 Cable Method

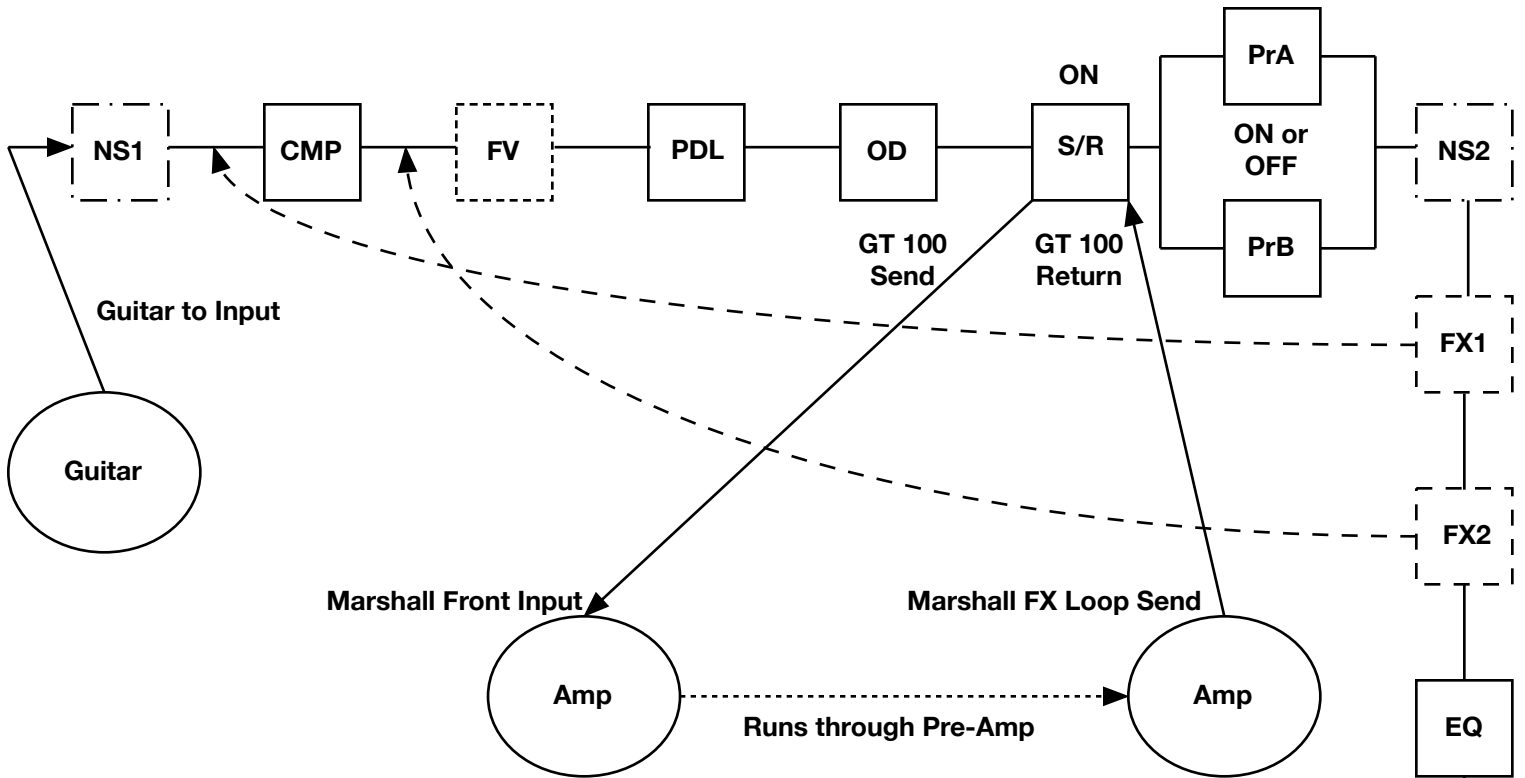

NS1/NS2: May be placed as seen in the picture. Check the effect settings.

FV: I prefer putting it before S/R, but you also can leave it behind PrA/B, to have Master Volume control.

FX1/FX2: Depends on the settings. You may also leave them at original positions. I always put NS1 in front of the FX chain, FX1 behind.

DLY/CHO: Order depends on what you want to achieve.

RVB: Should be placed at the end of the signal chain.

If you want to use only Marshall channels, you can disable PreA/B and put System-Input-Level to 0dB. If you want to get most patches from GT 100, put the level to something like -14dB. The input level should be adjusted, as if you plugged in your guitar directly to the Amp.

In fact, all modulation effects may vary in position depending on the sound you like. This is just an example, how it could look like. The 4 cable method is ideal, if you want to use the Marshall Overdrive sound.

